



We looked at the best and made it better...A LOT BETTER!

Deka has set a new standard for battery life in scrubber/sweeper applications. Over 50% longer life than the best selling battery! This means significantly lower battery replacement costs.

Our engineers went back to the drawing board to design a scrubber/sweeper battery from the ground up that will withstand the punishing demands of these applications. We've made a dozen design changes that really make the difference.



- There's a complete line of 6- and 12-volt sizes available, **wet and bone dry**, including replacement sizes for Advance, Clarke, Tennant and many others.
- New super-insulating, micro-porous polyethylene **envelope separators** protect the plates, eliminate short circuits and **dramatically extend battery life**.
- Positive plates are **glass wrapped**, similar to motive power industrial batteries. The glass fibers imbed themselves into the surface of the plate to **add reinforcement**... like "re-bars" in concrete. This reduces plate shedding and **extends life**.
- An **optimized balance** of the crucial **active material** on the plates means that the battery works harder and **lives longer**.
- The amount of **active material** on the positive plate has been **increased for added** performance and **life**.
- The manufacturing **process controls** have been **improved** for higher quality, performance and **life**.
- Even the **electrolyte** formula has been adjusted for **optimum balance** to extend **life**.
- More than **250 quality control checks** ensure the highest quality, and all Deka batteries are **made in the U.S.A.**

QUALITY SYSTEM
CERTIFIED TO
ISO 9001

ISSA MEMBER
The Experts
on Cleaning and Maintenance

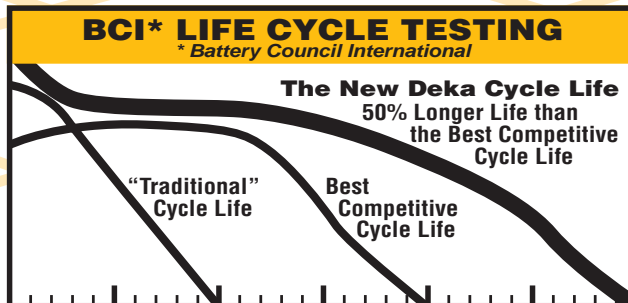

EAST PENN manufacturing co., inc.

Lyon Station, PA 19536-0147 • Phone: 610-682-6361 • Fax: 610-682-4781
Order Department Hotline: 610-682-4231
WWW: <http://www.eastpenn-deka.com> • E-mail: eastpenn@eastpenn-deka.com

DISTRIBUTED BY:

www.btekenergy.com
info@btekenergy.com

SCRUBBER/SWEEPER BATTERIES



SCRUBBER/SWEEPER BATTERIES

TYPE NO.		FOOT NOTES	STANDARD/OPTIONAL TERMINALS	PERFORMANCE LEVEL ♦♦					QUARTS (LITERS) OF ACID	APPROXIMATE WEIGHT lbs. (kgs.)		MAXIMUM OVERALL DIMENSIONS inches (mm)		
WET	DRY			20 AMP HR. RATE	6 AMP HR. RATE	MINS. DISC. @				WET	DRY	L	W	H
						75 AMPS	25 AMPS	23 AMPS						
6-VOLT FLOOR SCRUBBER AND SWEEPER														
8C11	8C11D	•	T881 / NONE	235	190	120	—	—	8 (7.6)	66 (29.9)	48 (21.8)	11¼ (298)	7 (178)	11½ (292)
9C11	9C11D	•	T881 / NONE	250	210	130	—	—	7½ (7.1)	72 (32.6)	52½ (23.8)	11¼ (298)	7 (178)	11½ (292)
8C6V	8C6VD	•	TSAE / ALL	330	270	170	—	—	10 (9.5)	97½ (44.2)	65½ (29.8)	11¼ (298)	7 (178)	14¼ (365)
8L16	8L16D	•	T882 / ALL	370	295	190	—	—	11½ (10.9)	113 (51.3)	83 (37.6)	11¼ (298)	7 (178)	16¼ (419)
GC10P	—	•	TSAE / ▲	190	156	100	—	—	—	59 (26.8)	—	10¼ (260)	7¼ (181)	10¼ (270)
GC15P	—	•	TSAE / ●	215	178	115	—	—	—	63 (28.6)	—	10¼ (260)	7¼ (181)	10¼ (270)
GC25G	—	•	T881 / NONE	235	—	132	488	—	—	67 (30.5)	—	10¼ (260)	7¼ (181)	11¼ (283)
GC45G	—	•	T881 / NONE	244	—	145	530	—	—	70 (31.8)	—	10¼ (260)	7¼ (181)	11¼ (302)
6-VOLT GEL CELL FLOOR SCRUBBER AND SWEEPER														
8GGC2	—	†	T881 / NONE	180	155	92	—	—	—	68½ (31.0)	—	10¼ (260)	7¼ (181)	10¼ (276)
12-VOLT FLOOR SCRUBBER AND SWEEPER														
8KFS	8KFSD	• H	TSAE / ALL	135	110	55	—	—	9 (8.5)	79 (35.8)	53 (24.0)	13¼ (346)	6¼ (171)	11½ (292)
8C12	8C12D	• H	TSAE / ALL	195	160	90	—	—	13 (12.3)	116 (52.6)	83 (37.6)	15¼ (394)	7 (178)	14¼ (362)
9C12	9C12D	• H	TSAE / ALL	228	180	115	—	—	12 (11.3)	127 (57.6)	95½ (43.3)	15¼ (394)	7 (178)	14¼ (362)
DC24	—	• HU	♦ MARINE / NONE	75	—	—	150	130	—	45 (20.4)	—	10¼ (273)	6¼ (171)	9¼ (238)
DC27	—	• HU	♦ MARINE / NONE	90	—	—	200	175	—	53 (24.0)	—	12¼ (318)	6¼ (171)	9¼ (238)
DC31DT	—	• HMT	♦ / NONE	105	—	—	225	185	—	59 (26.8)	—	13 (330)	6¼ (171)	9¼ (241)

SYMBOL DEFINITIONS:

- - Low maintenance - Low antimony grids
- ♦♦ - Rating after 15 cycles
- ♦ - Dual top terminals with TSAE post and stainless steel 3/8" stud and wing nuts
- ▲ - Available with T872 - order #GC10 Available with T881 - order #GC10G
- - Available with T872 - order #GC15 Available with T881 - order #GC15G

FOOTNOTES:

- H - Includes handles or lifting ledges
- M - Flush manifold vented cover
- T - Dual top terminals with SAE post and stainless steel 3/8" stud and wing nuts
- U - Offset post w/ vertical stainless steel 5/16" NEG., 3/8" POS stainless steel stud and wing nuts

All batteries manufactured with polypropylene cases except where noted.

† - **IMPORTANT CHARGING INSTRUCTIONS: WARRANTY VOID IF OPENED OR IMPROPERLY CHARGED.** Do not install in a sealed container. Constant under or overcharging will damage any battery and shorten its life! Use a good constant potential, voltage-regulated charger. **For 6-volt batteries, charge to at least 6.9 volts but no more than 7.05 volts at 68°F (20°C).** The open circuit voltage of a fully charged 6-volt battery is 6.4V at 68°F (20°C). However, as the battery charges, the building internal pressure (voltage) causes resistance to the charge. Therefore, the on-charge voltage must be higher (at least 6.9V) to overcome this internal pressure (voltage) during charging.

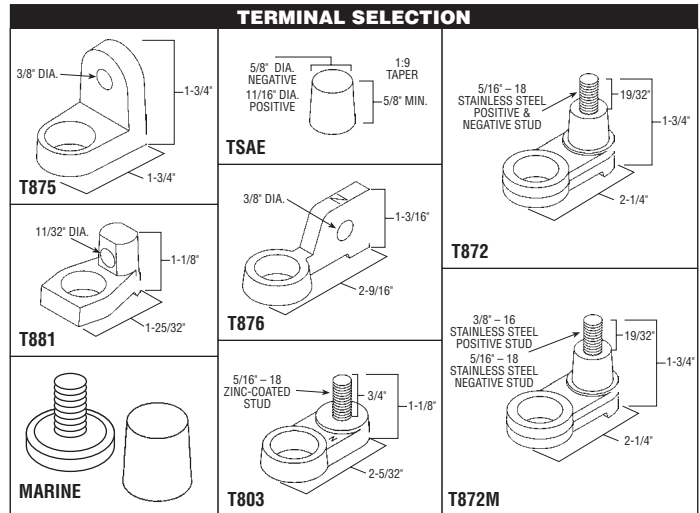

Type Number	BATTERY HEIGHT INCHES (mm) WITH OPTIONAL TERMINALS							
	TSAE	T881	T803	T872/T872M	T875	T876	T882	
8C6V	14¼ (365)	14¼ (371)	14¼ (371)	15¼ (387)	15¼ (390)	14¼ (371)	14¼ (375)	
8L16	16¼ (409)	16¼ (416)	16¼ (416)	17 (432)	17¼ (435)	16¼ (416)	16¼ (419)	
GC10P	10¼ (270)	10¼ (276)	—	11¼ (289)	—	—	—	
GC15P	10¼ (270)	10¼ (276)	—	11¼ (289)	—	—	—	
8KFS	11¼ (292)	11¼ (298)	11¼ (298)	12¼ (314)	12¼ (317)	11¼ (298)	11¼ (302)	
8C12	14¼ (362)	14¼ (368)	14¼ (368)	15¼ (384)	15¼ (387)	14¼ (368)	14¼ (371)	
9C12	14¼ (362)	14¼ (368)	14¼ (368)	15¼ (384)	15¼ (387)	14¼ (368)	14¼ (371)	